

# RECLAIMERS

## **AGGREGATE RECLAIMERS**

- \*SAVES WASHOUT WATER
- \*REDUCES DISPOSAL COST
- \*PROTECTS THE ENVIRONMENT
- \*SAVES WASHOUT TIME

*Over 30 years of  
Ready Mix Reclaimer  
experience!*





**SPECIAL DESIGN TAIL BEARING ASSEMBLY  
HEAVY DUTY AGITATOR PADDLE'S  
LONG-WEARING, REPLACEABLE SHOES  
POLYURETHANE ON 24"  
NI-HARD CAST ON 36"**

**24" MODELS HAVE VIBRATING SCREEN TO SEPARATE ROCK AND SAND  
36" MODEL WILL HAVE ROCK AND SAND WASHED TOGETHER**

Special design tail bearing assembly on all models, located inside classifier trough with no packing or seals outside the classifier wall. Tail bearing can be easily raised without being taken loose from classifier wall.

The customer can choose the slurry recovery system that best fit their needs.

## Pond Sketch

1. Settling ponds will allow cement fines to settle out.
2. Agitators for slurry pond.
3. 100% reclaim systems (Consult factory for details).

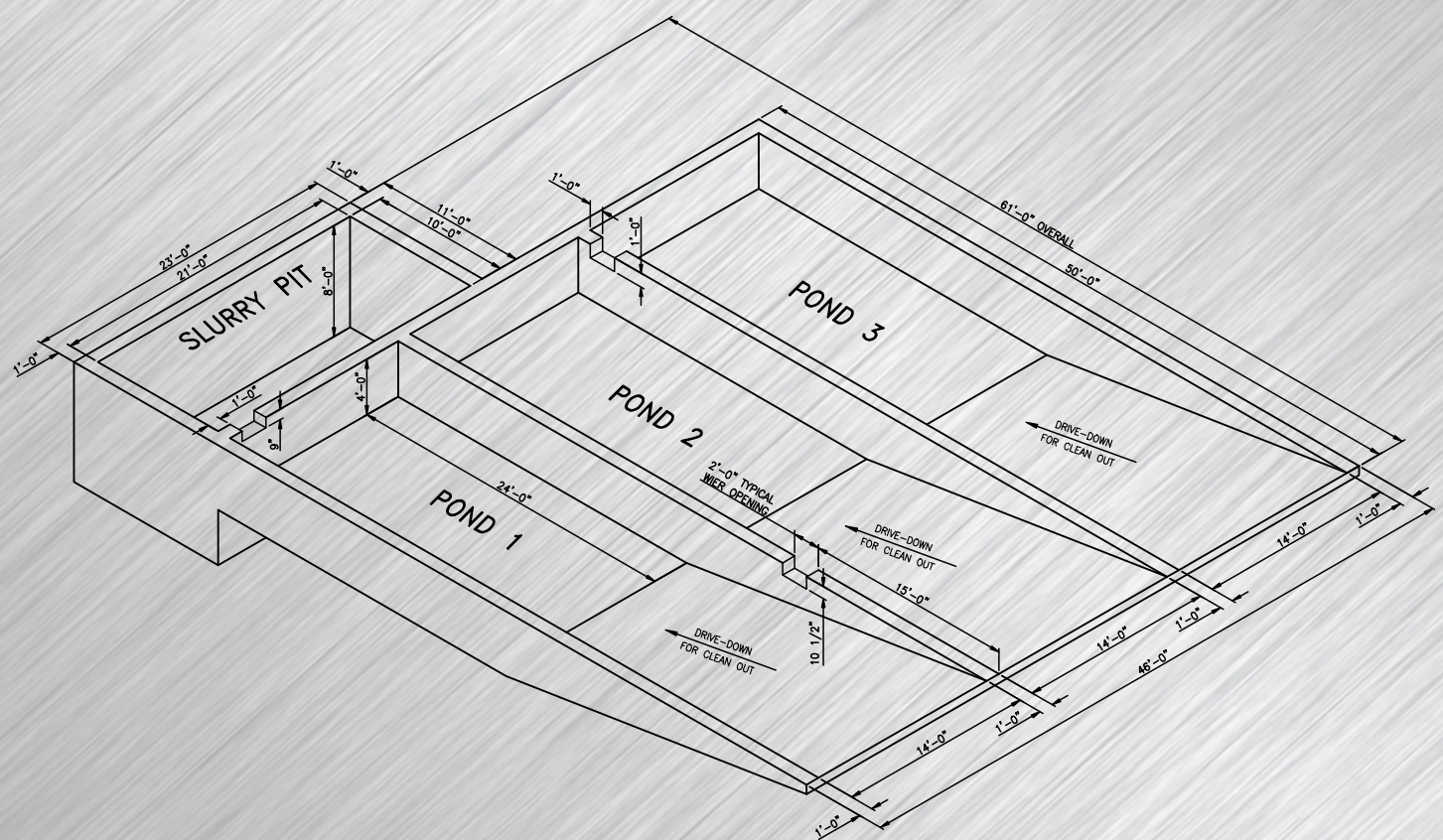

ISOMETRIC VIEW (3) STAGE SETTLING POND WITH SLURRY PIT

# Why a Stephens?

- Owned by Stephens family since 1957
- Reputation of honest, reliable and second to none sales and service
- In-house CNC/Machine shop
- Certified in-house scales to keep load cell size and quantity down
- Simple and easy to service and maintain, features standard off the shelf parts
- Each plant is designed for your seismic requirements

Proud Members of



**Stephens**

**Stephens**  
CONCRETE PLANTS • Tompkinsville, KY  
Stephens Manufacturing

